

RECOMMENDED PCB LAYOUT
TOLERANCE UNLESS OTHERWISE IS ±0.05

- :PAD AREA
- :GND PATTERN ONLY
- :KEEP OUT AREA
- :NO COPPER AREA (NO Trace&Via&GND)

PIN DEFINE:

PIN#	NAME	DESCRIPTION	PIN#	NAME	DESCRIPTION
1	VSS3	GROUND	11	VDD1	SUPPLY VOLTAGE
2	DAT2	DATA LINE BIT2	12	D1-	DIFFERENTIAL DATE 1-
3	DO+	DIFFERENTIAL DATE 0+	13	CLK	CLOCK
4	CD/DAT3	CARD DETECT/DATA LINE BIT3	14	D1+	DIFFERENTIAL DATE 1+
5	DO-	DIFFERENTIAL DATE 0-	15	VSS2	SUPPLY VOLTAGE GROUND
6	CMD	COMMAND/RESPONSE	16	VSS5	GROUND
7	CD	CARD DETECT	17	DAT0	DATA LINE BIT0
8	VSS1	SUPPLY VOLTAGE GROUND	18	DAT1	DATA LINE BIT1
9	VSS4	GROUND	19	WP	WRITE PROTECT
10	VDD2	SUPPLY VOLTAGE(1.8V)			

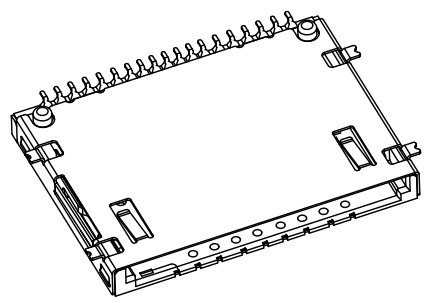
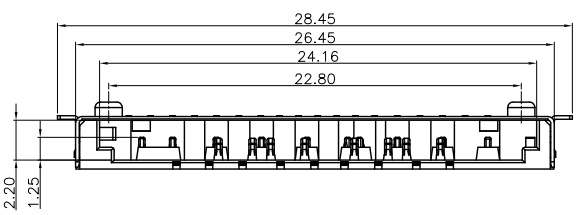

- PART.NO.: TW221-AP401-**
- 42: 功能区镀金1U", 锡脚镀雾纯锡至少80U"
 - 43: 功能区镀金3U", 锡脚镀雾纯锡至少80U"
 - 44: 功能区镀金5U", 锡脚镀雾纯锡至少80U"
 - 45: 功能区镀金10U", 锡脚镀雾纯锡至少80U"
 - 46: 功能区镀金15U", 锡脚镀雾纯锡至少80U"
 - 47: 功能区镀金30U", 锡脚镀雾纯锡至少80U"

- NOTES :
- MATERIAL :
 - HOUSING:LCP UL94 S475 V-0, BLACK COLOR.
 - SHELL:STAINLESS STEEL SUS304.
 - CONTACT:COPPER ALLOY C5210.
 - FINISH :
 - CONTACT: GOLD PLATING ON CONTACT AREA, MATTE TIN 80u"MIN ON SOLDERTAIL AREA. 50u" MIN NICKEL PLATING OVERALL.
 - SHELL: 30U" MIN SOLDERABLE NICKEL PLATED OVER ALL.
 - ELECTRICAL CHARACTERISTICS:
 - OPERATING VOLTAGE : 100V AC(rms)/DC.
 - CURRENT RATING : 0.5 A.
 - OPERATING TEMPERATURE: -25°C~+85°C.
 - CONTACT RESISTANCE: 100 m OHMS MAX.
 - INSULATION RESISTANCE: 1000M OHMS MIN. AT 250VDC.
 - DIELECTRIC WITHSTANDING VOLTAGE:500 VAC/1MINUTE.

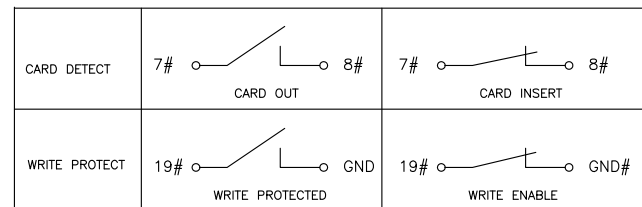

GENERAL	TOLERANCE	DWG.NO.	TW221-AP401-00	PART.NO.	TW221-AP401-**	DRAWN	Ervin 2020.07.10	UNIT	mm	SCALE	1:1
.x±0.50	x. °±5°	REV.	A	TITLE	SD4.0 No Push H2.95反向型	CHECKED		东莞市欧联电子科技有限公司 DONGGUAN OLN ELECTRONICS TECHNOLOGY CO., LTD.			
.x±0.25	.x °±2°	SIZE		SHEET	1 OF 2	APPROVED					
.xx±0.15	.xx °±1°	A4									

东莞市欧联电子科技有限公司

包装作业规范

REV.	ECN.NO.	MODIFY.CONTENT
------	---------	----------------

包装作业图示及说明 (PACKING OPERATION DIAGRAM & INSTRUCTION)

- 一.
- 1) 将成品一一放入REEL包装盘内,依同一方向放入.
 - 2) 包装时,如图所示.
 - 3) 一个REEL包装盘放置380个成品.

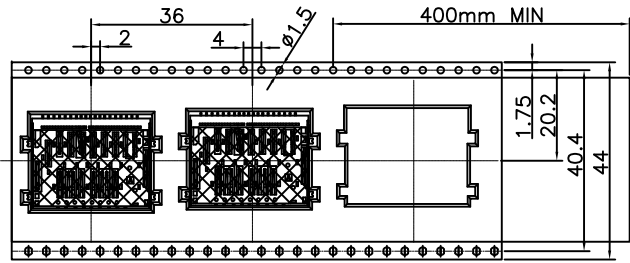

- 三.
- 1) 每箱装6盘REEL包装盘.
 - 2) 每箱放置2280PCS的成品.

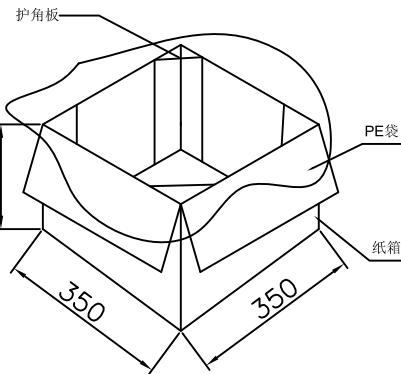
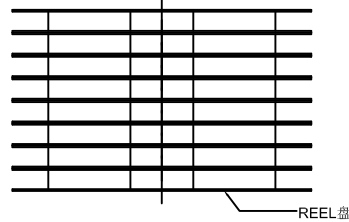

- 二.
- 1) 装盘前先把前面空10pcs产品,然后再开始装盘, 尾端也需空12pcs产品,上带加长200mm.
 - 2) 装满成品的REEL包装盘如下图所示.

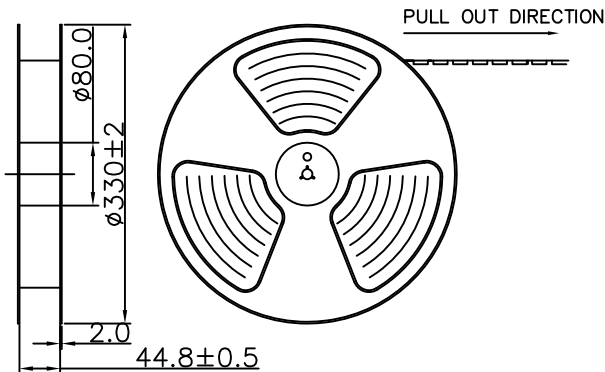

- 四.
- 1) 用TAPE将纸箱封实.

ITEM NO:	PCS
Q'TY.:	KGS
G.W.:	KGS
N.W.:	KGS
MEAS:	cm

C/NO: MADE IN CHINA	

备注 (REMARK)

1. 若有未装满之零数箱,必须以缓冲材塞满.

GENERAL TOLERANCE	TW221-AP401-00	PART.NO.	TW221-AP401-**	DRAWN	Ervin 2020.07.06
x.±0.50	REV.	TITLE	SD4.0 No Push H2.95反向型	CHECKED	
.x±0.25	SIZE	SHEET	2 OF 2	APPROVED	
.xx±0.15	A4				

UNIT	mm	SCALE	1:1
东莞市欧联电子科技有限公司 DONGGUAN OLN ELECTRONICS TECHNOLOGY CO., LTD.			